

### LF-168L

#### 鍋具類專用油壓鉚釘機

- 特製工作台，方便鍋具類上下料。

#### Hydraulic Riveting Machine Special for Pan

- Special workable design, it is convenient for pan loading and unloading

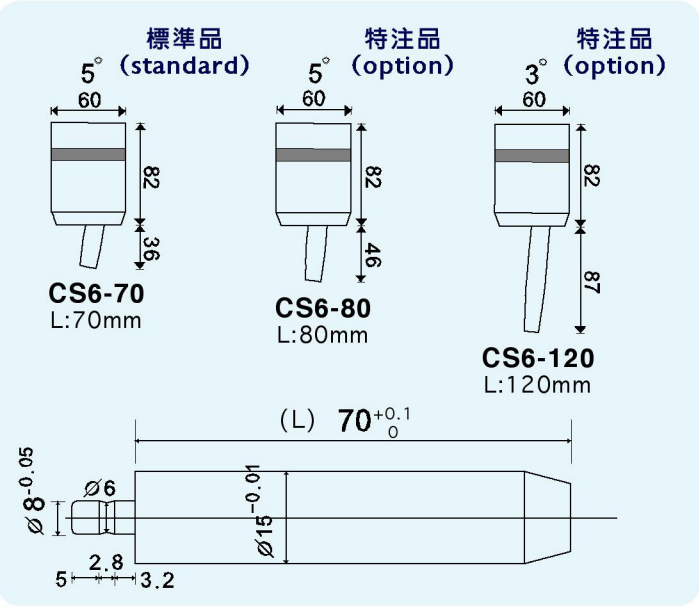
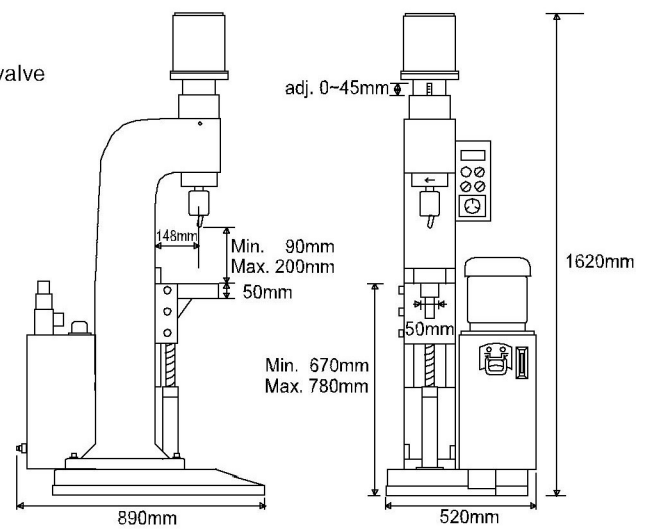

#### 規格 SPECIFICATIONS:

夾頭行程 Stroke of spin head (mm)	鉚合能力 Riveting capacity (Mild Steel Rivet) (mm)	沖頭至台面距離 Distance between punch and table (mm)	喉 深 Depth of throat (mm)	馬 達 AC motor rating 4 poles 3 Phase	使用壓力 Gauge pressure (kgf/cm <sup>2</sup> )	最大出力 Max. output (kgf)	時間設定 Working cycle time (second)	機 械 尺 寸 Dimension LxWxH (mm)	淨 重 N.W. (Kgs)	裝 箱 尺 寸 Wooden Case LxWxH (mm)	毛 重 G.W. (Kgs)
0-45	實心(Solid) 3-12 空心(Hollow) 3-20	90-200	148	Spindle 1 HP Pump 2 HP	10-70	1980	0.5-6	890x520x1620	360	990x620x1770	415