

LF-162-3A

經濟型油壓鉚釘機

- 機身與油箱分開設計，需要時可上下分離，更改為專用機使用時，容易施工。
- 最大鉚合能力，實心釘達 $\phi 12\text{mm}$ 。

Economic Type Hydraulic Riveting Machine

- Separate design for machine body and oil tank. If necessary, they can be separated from each other and changed into a special-purpose machine for use. It's easy to have such a change.
- Max. riveting capacity up to $\phi 12\text{mm}$ rivets.

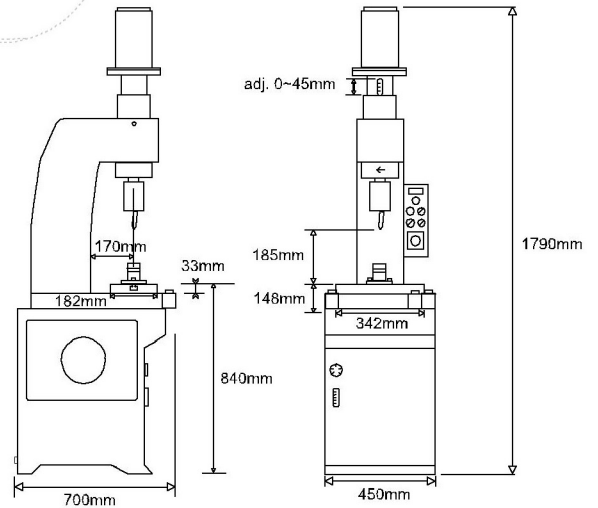
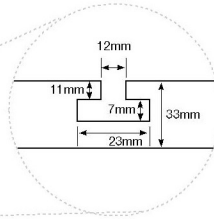

Above: actual example of processing
加工實例如上圖

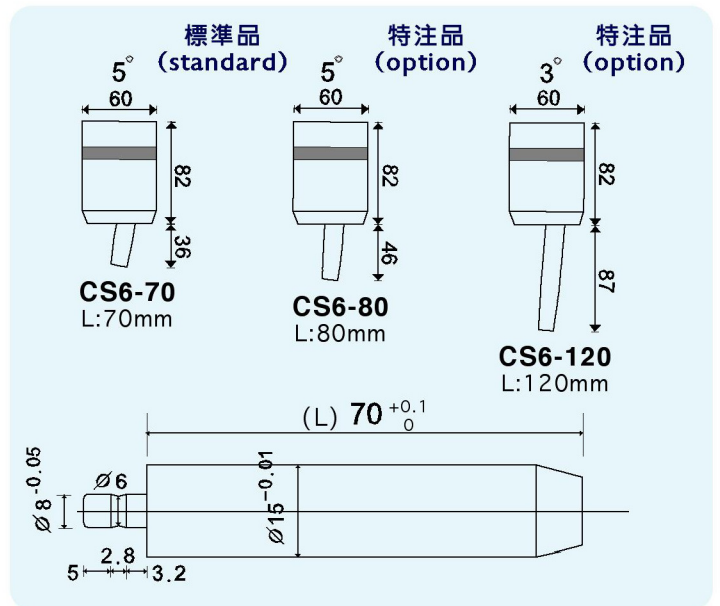

規格 SPECIFICATIONS:

夾頭行程 Stroke of spin head (mm)	鉚合能力 Riveting capacity (Mild Steel Rivet) (mm)	沖頭至台面距離 Distance between punch and table (mm)	喉深 Depth of throat (mm)	馬達 AC motor rating 4 poles 3 Phase	使用壓力 Gauge pressure (kgf/cm ²)	最大出力 Max. output (kgf)	時間設定 Working cycle time (second)	工作台尺寸 Working Table LxW (mm)	機械尺寸 Dimension LxWxH (mm)	淨重 N.W. (kgs)	裝箱尺寸 Wooden Case LxWxH (mm)	毛重 G.W. (kgs)
0-45	實心 (Solid) 3-12 空心 (Hollow) 3-20	185	170	Spindle 1 HP Pump 2 HP	10-70	1980	0.5-6	342x182	700x450x1790	315	790x540x1950	360