

### LF-188-3A

#### 雙段速重型油壓鉚釘機

- 龍門式機座，喉深長。鋼板機身，結構堅固。
- 附有大型風扇冷卻器，油溫不升高，油壓不衰退。
- 夾頭行程，為雙段速率設計，可減少夾頭負荷前的時間浪費，增加產能。
- 出力大，鉚合能力強，實心釘最大可達  $\phi 21\text{mm}$ 。

#### Two-Stage Speed of Heavy Duty Hydraulic Riveting Machine

- Planer type of machine base, big depth of throat, machine body of steel plate, strong structure.
- Equipped with big fan cooling system, so oil temperature will not rise and pressure will not reduce.
- The design of spin head stroke is a two-stage speed one, so the time before loading spin head can be shortened and the production can be increased.
- High output power, strong riveting capacity up to  $\phi 21\text{mm}$  rivets.

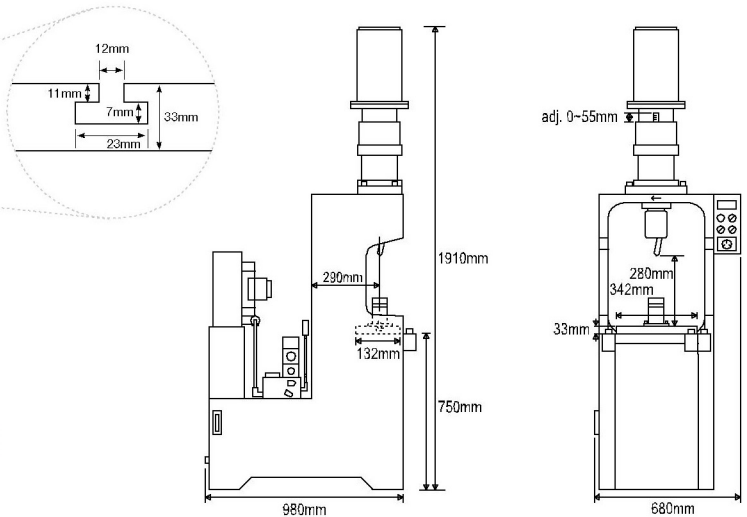

Above: actual example of processing  
加工實例如上圖

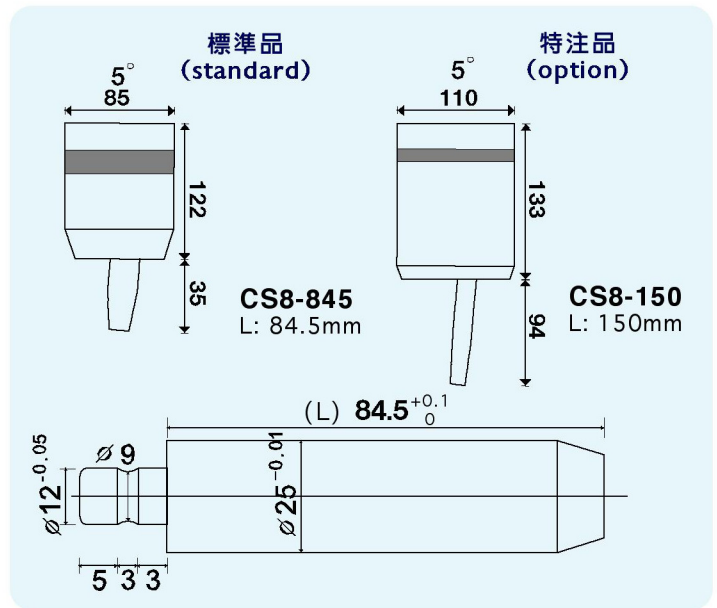

#### 規格 SPECIFICATIONS:

夾頭行程 Stroke of spin head (mm)	鉚合能力 Riveting capacity (Mild Steel Rivet) (mm)	沖頭至台面距離 Distance between punch and table (mm)	喉深 Depth of throat (mm)	馬達 AC motor 3 Phase	使用壓力 Gauge pressure (kgf/cm <sup>2</sup> )	最大出力 Max. output (kgf)	時間設定 Working cycle time (second)	工作台尺寸 Working Table LxW (mm)	機械尺寸 Dimension LxWxH (mm)	淨重 N.W. (kgs)	裝箱尺寸 Wooden Case LxWxH (mm)	毛重 G.W. (kgs)
0-55	實心 (Solid) 8-21 空心 (Hollow) 8-35	280	290	Spindle 2HP 6Pole Pump 2HP 4Pole	10-70	5270	0.5-10	342x182	980x680x1910	557	1080x770x2070	615